

F. G. BIELEFELD, H. A. EIBACH & H. VOGEL.
 Chuck Attachment for Lathes.

No. 217,048.

Patented July 1, 1879.

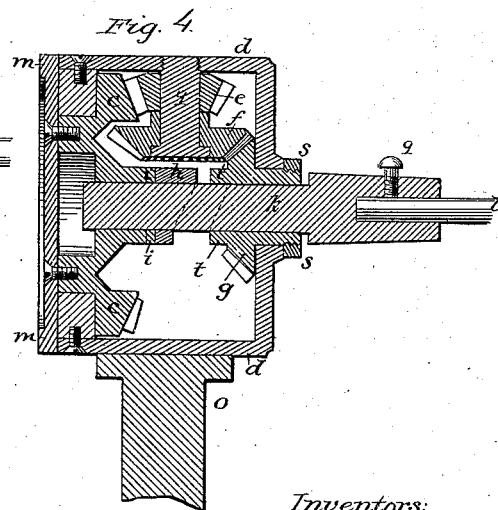
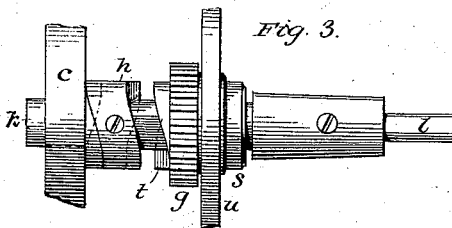
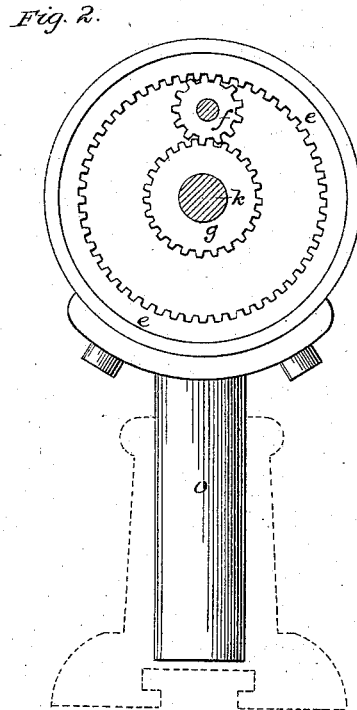
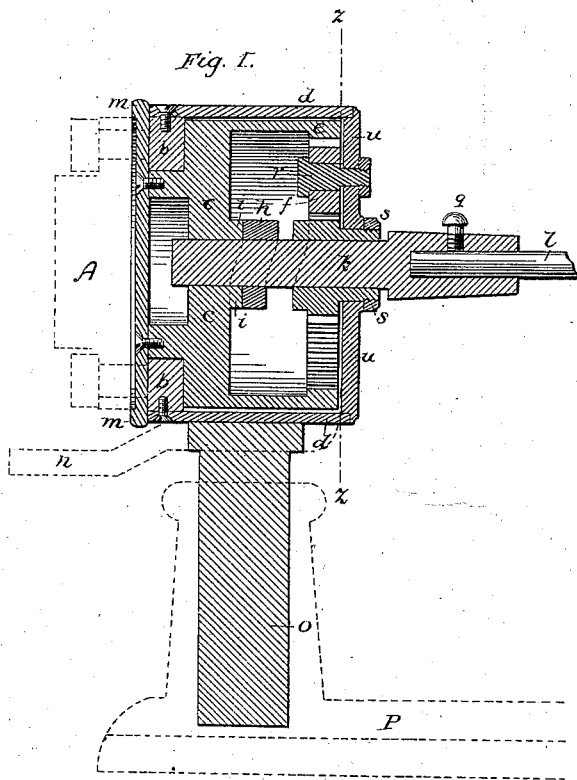

Attest:
 Clarence Poole
 R. N. Dyer.

Inventors:
 Frank G. Bielefeld.
 Hermann A. Eibach.
 Hugo Vogel.
 by Geo W Dyerole. atty.

UNITED STATES PATENT OFFICE

FRANK G. BIELEFELD, HERMANN A. EIBACH, AND HUGO VOGEL, OF CHICAGO, ILL.; SAID BIELEFELD AND VOGEL ASSIGNORS TO SAID EIBACH.

IMPROVEMENT IN CHUCK ATTACHMENTS FOR LATHES.

Specification forming part of Letters Patent No. 217,048, dated July 1, 1879; application filed June 18, 1878.

To all whom it may concern:

Be it known that we, FRANK G. BIELEFELD, HERMANN A. EIBACH, and HUGO VOGEL, all of Chicago, in the county of Cook and State of Illinois, have invented a new and Improved Chuck Attachment for Lathes, which improvement is fully set forth in the following specification, reference being had to the accompanying drawings, in which—

Figure 1 represents a longitudinal vertical section of our device; Fig. 2, a sectional view on line $z z$ in Fig. 1; Fig. 3, a detail view of the tap or bolt holding spindle, and Fig. 4 a modification in the arrangement of the gearing.

The nature of our invention relates to screw-cutting machinery, and particularly to devices for reversing the rotation of the tap or bolt chuck; and it is our object to so construct such chucks that the same can be attached to a common turning-lathe, and that from a continuous rotating motion of the lathe-mandrel in one direction an alternate rotation in opposite directions and of different speed can be imparted, for the purpose of obtaining a slow-cutting and a quick-receding motion for the tap.

Our invention consists in the combination, with a suitable casing, of a disk and wheel situated at the ends of the casing, and provided with clutch-teeth on their inner faces, the disk being adapted for connection with the face-plate of a lathe, a sliding tap or bolt chuck-spindle passing loosely through said disk and wheel, and having a double clutch secured upon it between the clutch-teeth of the disk and wheel, and gears connecting the said disk and wheel, so that they will turn in opposite directions, as fully hereinafter explained.

In the drawings, k represents a spindle, arranged with a socket for inserting either the tap l or the bolt to be screw-threaded, and for holding the same by means of a set-screw, g . This spindle is passed through the hub of gear-wheel g , having clutch-teeth t , and through the central eye of a disk, c , having clutch-teeth i , so as to have a free rotating and longitudinal motion therein. A sleeve, h , is secured upon said spindle k , the ends of which are provided with teeth, for coupling with either one of the clutch-teeth of disk c or wheel g by longitudinal shift of said spindle.

d is the cylindrical casing, having a leg, o , adapted to be inserted and secured in the tool-rest socket of a turning-lathe, and a steadying-brace, n , for connection with the head-stock. To these devices for rigidly holding said casing to the lathe-bed we do not wish to be restricted. The front end of this casing d is closed by a plate, u , the center of which is bored out for the hub of wheel g , which is projected through the same, so as to rotate therein, and is longitudinally secured in its position by a ring-collar, s , screwed upon the end of said hub. A ring-flange, b , is held in the rear end of the casing d by a series of screws, and the disk c is provided with an annular concentric flange, which is fitted to turn in said ring-flange b and act as the journal of said disk, which is prevented from longitudinal movement by a plate bolted against the annular flange of said disk. This plate is to be bolted or otherwise secured to the face-plate A of the turning-lathe, so as to rotate therewith, it having an annular rim-shoulder, m , to fit over the rim of the face-plate A, and hold the same in a concentric position therewith. The ring, e , having internal gearing-teeth at one end, is with its other end secured upon the rim of disk c , it being of such length that its gearing-teeth are vertically in line with the teeth of gear-wheel g , and motion is transmitted from one to the other of said wheels by a pinion, f , interposed between, so as to engage with the teeth of both wheels. This pinion f rotates on a pin, r , which is secured to plate u .

In the modified device, Fig. 4, the difference of speed and reversed motion is brought about by bevel-gearing in place of spur-wheels, in which case the bevel-wheel c is substituted for the disk c , and imparts motion to the bevel-wheel g , of an increased speed and in opposite direction, by two bevel-pinions, e and f , rigidly coupled together, and rotating on a fulcrum-pin, q , which is secured to the internal face of the cylindrical casing d .

As will be noticed, this machine can be readily secured to any common turning-lathe, so as to be driven by the mandrel of the same, and while said lathe-mandrel is continuously rotating in one and the same direction, the tap or bolt chuck-spindle k can be caused to turn in

either direction by shifting the same so as to be coupled either with the disk *c*, when its motion will be the same as the mandrel of the lathe, or by pulling it forward so as to disengage from said disk *c* and to couple with the wheel *g*, when its direction of motion becomes reversed and its speed of rotation more than doubled. The slow motion of said spindle is to be applied for cutting the screw-thread, while its reversed motion of increased speed is intended for the receding of the tap or bolt, whereby much otherwise idle time is saved.

The above device is simple in construction, and, as it can be quickly attached to any common turning-lathe, it will save the expense and space of an extra screw-cutting machine.

What we claim as our invention, and desire to secure by Letters Patent, is—

The combination, with the casing, of the disk *c* and wheel *g*, situated at the ends of the casing and provided with clutch-teeth on their inner faces, the said disk being adapted for connection with the face-plate of a lathe, the sliding spindle *k*, passing loosely through said disk and wheel and having a clutch, *h*, and gears connecting the disk and wheel, so that they will turn in opposite directions, substantially as described and shown.

FRANK G. BIELEFELD.
H. A. EIBACH.
HUGO VOGEL.

Witnesses:

C. SILET,
CHAS. T. NICKEL.